



Is Your Packaging Part Of The Problem?

Let's Unpack Sustainable
Packaging Solutions





**#1 COMPANY IN INDIA
EXPORTING IN MORE THEN 70+ COUNTRIES**



**INTERNATIONAL
PACKAGING AWARDS**



**AmeriStar
2016**



**2018
Pentawards
Gold**



**DUPONT
PACKAGING
AWARDS**



**UK PACKAGING
AWARDS**



**FPA Flexible
Packaging
Association Award**

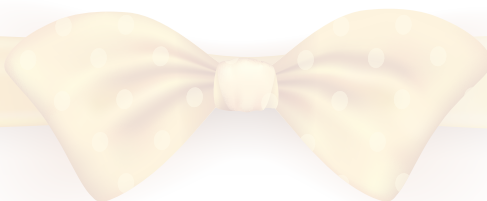

1 - Are You Looking To Pack Your Products Choose Any One Material From Below

A) **PLANTMADE™** MADE FROM PLANTS



Compostable Material

- We manufacture Compostable bioplastic packaging that will break down naturally when left in the right environment. Unlike traditional plastic packaging, it is made from organic materials that break down in a reasonable period of time and leave no toxic chemicals or harmful particles behind.
- Note: Not suitable for oily, liquid products & Products that require long shelf life.

B) **Papermade™** Plastic Free Packaging



Plastic Free Paper Material

- In the past, the focus of food packaging was to provide branding, protection, storage and transportation. Now, the focus has shifted to promoting circular economy and utilizing sustainable raw materials Papermade pouches offer a packaging solution that simultaneously protects and preserves the environment.
- Our Papermade pouches have a low & Medium barrier capacity.
- Papermade pouches are well suited for secondary packaging, outer packaging or it is used to pack light weight products like chocolate & energy bars.
- Use paper where possible, plastic when useful.

C) **WISSLOOP™** Designed for Recycling



Recyclable Material

- 100% Recyclable flexible pouches are a step in the right direction for all the environment conscious businesses who require affordable packaging.
- In the majority of cases, this material serves as a viable substitute for non-recyclable packaging, offering a sustainable alternative that aligns with eco-friendly practices.
- This will not only help your brand image but also contribute towards a circular economy and Zero Waste future.
- *We can also manufacture recyclable bags with upto 80% recycled Plastic raw material (PCR).

D) **WASTEmade™**
Made Using Recycled Materials

Made using plastic Waste Material



- **WASTEMADE** is made up of recycled materials (PCR)
- By using **WASTEMADE** materials, we are helping to reduce the amount of plastic waste that ends up in our ocean and landfills
- PCR (Post-Consumer Recycled) Pouches are paving the way for a Circular Economy.
- By utilizing PCR materials, these pouches effectively divert waste from landfills & Cleans up our planet.

E) **S'protek™**
For Ultimate Protection

Plastic & Paper High Barrier Material



Conventional / Linear Material

- Multilayer plastic lamination offers a cost-effective packaging solution with customizable barrier properties that extend the shelf life of perishable products.
- The different layers in the lamination can be tailored to provide specific barrier properties, such as oxygen and moisture resistance, according to the product's requirements.
- This not only helps to minimize spoilage and maintain product freshness but also ensures that the packaging provides optimal protection at a competitive price point.

**SUSTAINABLE
PACKAGING SOLUTIONS**

2 - Now Choose Any One Printing Technology

F) Laser Printed Pouches / Rolls

Minimum 1000 Pieces

**Print Tech
CMYK+O+V+W
(4+1+1+1 Colours)**



- Minimum Quantity 1000 pieces / In Rolls 50 kgs
- There is No Cylinder / No Printing Plate Cost
- Variable data capability (names, addresses, unique QR code, sequential numbering system)
- Quick on-the-fly graphic changes
- Ultra short volume run is possible

Check prices, upload your custom designs and buy online below.

<https://www.swissonline.co.in/digital-printed-pouches.html>



G) Rotogravure Printed Pouches / Rolls

Minimum 10,000 +

**Print Tech
CMYK+W+PMS
(4+1+4 Colours)**



- Minimum Quantity 10,000 pieces / In Rolls 300 kgs
- Most economical on low to high volume runs
- Ideal for product lines that run without significant design changes.
- Recommended for High Quality HD Graphic design printing, High speed and repeatability.
- A larger variety of material types with custom print finishes is possible
- Precise colour matching in Pantone Shades.

Enquire about this product on below link.

<https://www.swissonline.co.in/what-you-want-to-pack>



H) Ready To use Stock Pouches in Different Colours and sizes



- Starting a business? NO WORRIES!!!! The Simplest Way - DIY
- Using unprinted bags/ pouches and adding Labels is a simple and budget-friendly way to introduce your product to the market. Simply choose your pouch style, size, colour, material and quantity.

Click below to buy this product online

<https://www.swissonline.co.in/stock-products>

H.1) Custom Printed Labels



- Minimum Quantity 500 pieces in multiple design



- We offer a wide range of label materials, various shapes, and an extensive selection of print finish options to suit the needs of diverse industries.
- Our label solution are perfect for businesses operating in food, cosmetics, pharmaceuticals, nutraceuticals, pet food, and other sectors.
- When dealing with multiple product variants, labels offer a cost-effective and efficient solution for branding your packaging.

Click below to buy this product online

<https://www.swissonline.co.in/custom-sticker-printing.html>

H.2) Static Printed Bags & Foil Stamping On Bags



- The MOQ is 500 pieces.
- Static printing is a suitable option for non-graphic vector design.
- Simple design with solid lines and colour with up to 2-4 colour.
- Recommended for small startup businesses

Enquire about this product on below link.

<https://www.swissonline.co.in/what-you-want-to-pack>

3 - Style Of Bags & Print Finish Options

I) Explore different range of bags style by clicking below link.

<https://youtu.be/44uny9Vlrcl>



J) Discover the world of printing effects by clicking below link

<https://youtu.be/1nKln-cu4mE>

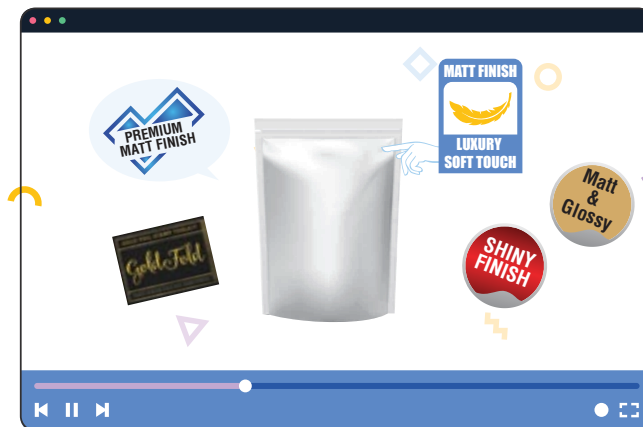

K.1) Temper Proof Sleeves On Cap



K.2) Temper Proof Label With Cap



K.3) Labels On Uneven Shaped Bottles



- Minimum order quantity starts from 1000* pieces.
- 100% Recyclable Shrink Labels are a step in the right direction for all the environment conscious businesses.
- Shrink sleeves are ideal for containers with uneven surfaces where traditional labels won't adhere due to the packaging's irregular shape.



Click & Explore This product

<https://www.swissonline.co.in/custom-plastic-pet-pvc-shrink-sleeve-labels>



L) - Machines

Small or large scale, we have got you covered with our range of automatic filling, sealing, & coding machines.

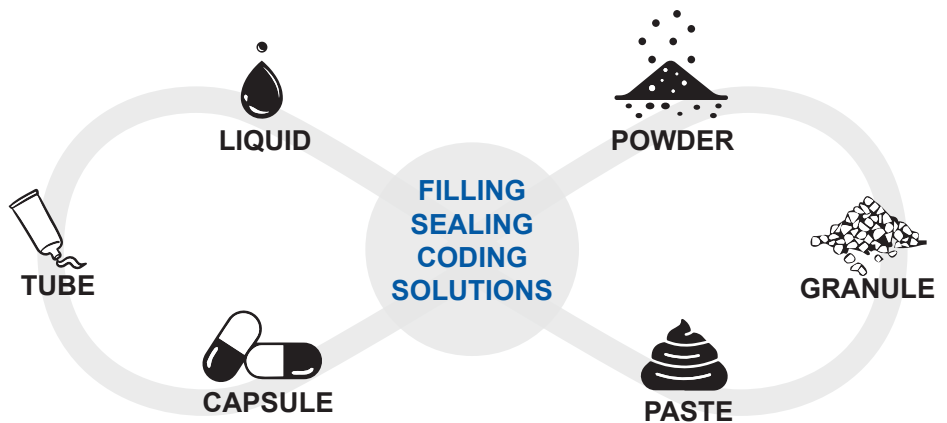

L.1) Filling Machines

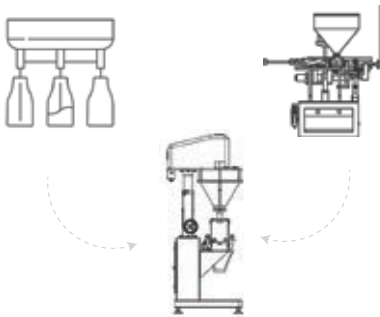

L.2) Sealing Machines

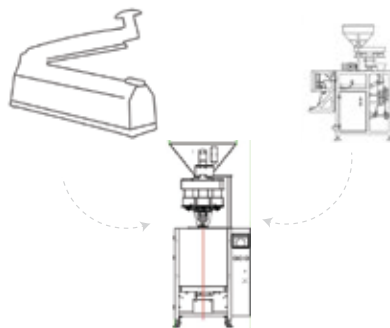

L.3) Coding Machines

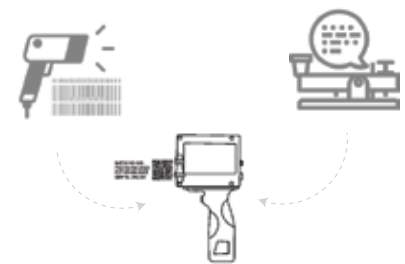

Click below to buy filling, sealing and coding machines online.

<https://www.swissonline.co.in/heat-sealing-machine>



M) Paper Folding Cartons



- Minimum Quantity 5000 pieces.
- No Printing Plate Cost.
- A larger variety of material types with custom print finishes is possible
- Our cartons solution are perfect for businesses operating in food, cosmetics, pharmaceuticals, nutraceuticals, Personal Care, and other sectors.

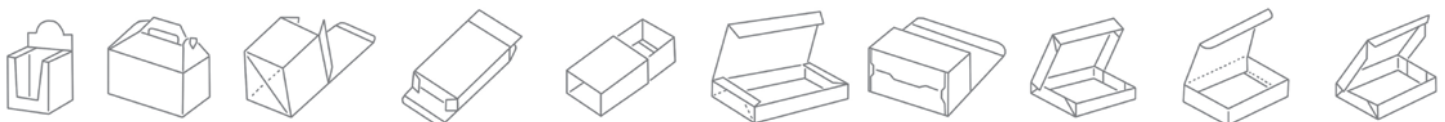

Click below to buy filling, sealing and coding machines online.

<https://www.swissonline.co.in/paper-folding-cartons>



N) Adhesive Tapes



Get price buy online

<https://www.swissonline.co.in/bopp-tape-6-rolls.html>



P) Vacuum Bags



Get price buy online

<https://www.swissonline.co.in/vacuum-bags.html>



O) Jumbo Size Bags For Warehouse Storage



Get price buy online

<https://www.swissonline.co.in/jumbo-size-bulk-storage-bags.html>



Q) Recycled Courier Bags

Custom Printing Starts from 500 pieces*



Get price buy online

<https://www.swissonline.co.in/plastic-mailing-envelopes.html>



R) Measuring spoons : For accurate dosage



Get price buy online

<https://www.swissonline.co.in/measuring-scoops.html>



S - Creative Services

Whether you need a small-scale package design or a grand branding venture, our Creative Team is prepared to cater to your needs without limitations.

Your Brand Is Your Foundation

Our vibrant creative company, specializes in a comprehensive suite of services, such as branding, package design, e-commerce website development, corporate video shooting, and an array of other inventive solutions.



Offering a wide range of services from package design to web development and social media management. Our dedicated Creative Team is ready to assist you in bringing your ideas to life. With over 30 years of industry experience, our flexible packaging experts will provide valuable insights. Our Creative Services Team is skilled in branding and brand strategy, packaging design, graphic design, website design, social media management, content writing, pay-per-click advertising (PPC), and search engine optimization (SEO).

Click below for creative services pricing.

<https://www.swissonline.co.in/design-services>





Click To Check Our Production Video

<https://youtu.be/CUxhFfrVRBs?si=qAr4HqJJztWWUU5y>



Trusted by Brands



DEVELOPMENT AND QUALITY ASSURANCE

Our manufacturing sites are accredited with
FSSC 22000-2010, ISO 22000-2018,
ISO 14001-2015, WHO-GMP, and HACCP standards,
 When it comes to exporting to the USA and Europe, our packaging
 materials have verified certifications, providing the necessary documentation
 for seamless cross-border trade.



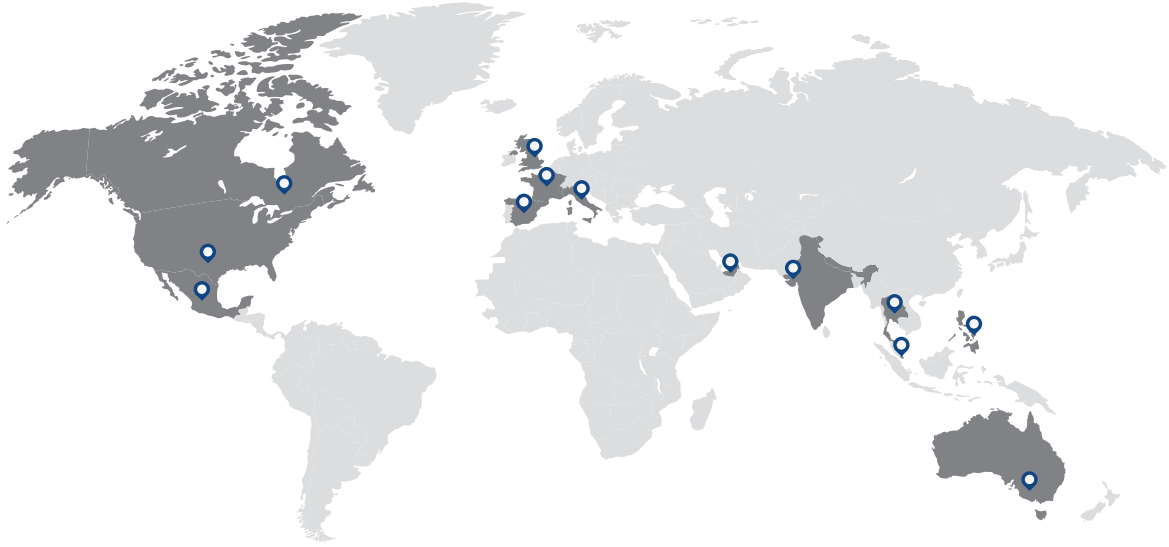

Our global operations span 3 manufacturing units and 13 offices worldwide.

SWISSPAC is dedicated to providing the most sustainable and suitable packaging solution to

SWISSPAC was founded in the early 90's to provide eye-catching flexible packaging to cater small and medium scale artisan brands. Since its humble origins, the company has evolved to become a large global packaging manufacturer and now has 500 employees. Our manufacturing unit is spread across 4,00,000 square feet. We export our products to more than 70 countries & 80% of our products are exported internationally. We now serve more than 4,000 brands worldwide.



Padra - Jambusar Highway, At Dabhasa Village,
Vadodara, Gujarat - 391440, INDIA

tel:+91 93138 00614
tel:+91 74909 77640



tel:+91 93138 00615
tel:+91 96876 31456

swisspack.co.in

swissonline.co.in

Order our **free samples** online below and discover their quality by yourself

<https://www.swissonline.co.in/sample-page>

scan this QR code to pay 250 rupees as a courier cost and request for free samples.

